





ASSEMBLY INSTRUCTIONS | VIDA EXTENSION DINING TABLE

HARDWARE CHECKLIST		
A		Allen Key 5mm (1pc)
B		Bolt M8x16 (6pcs)
C		Washer ø8 (14pcs)
D		Bolt M8x12 (8pcs)

IMPORTANT: This unit requires at minimum 2 people to assemble 

Step 1

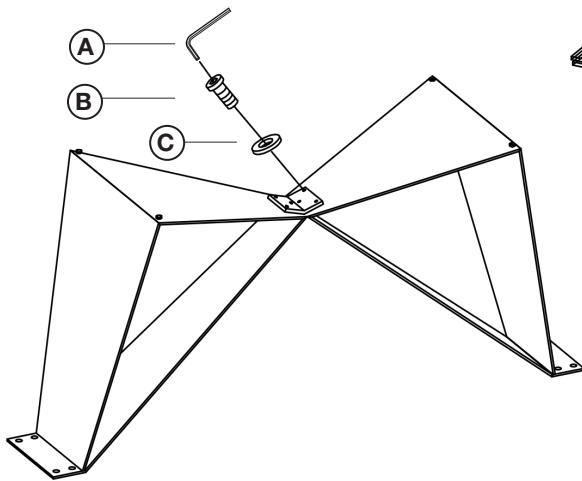

Step 2

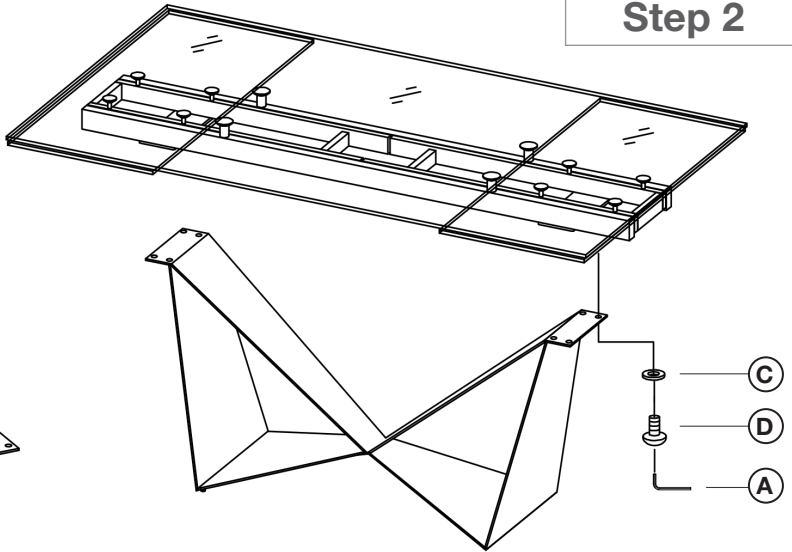

Finish

