

ASSEMBLY INSTRUCTIONS

ALINA SHAGREEN MEDIA SIDEBOARD

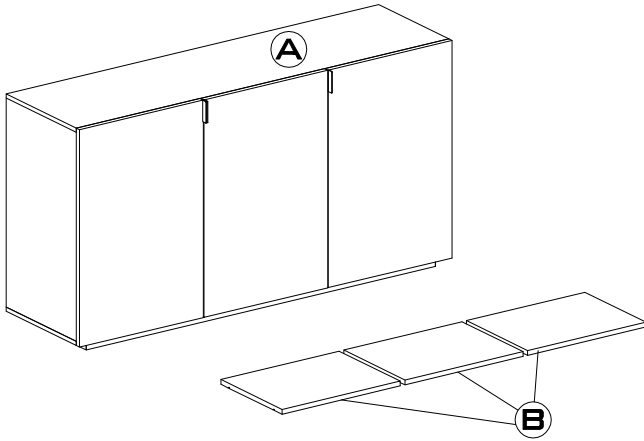

PARTS CHECK LIST

CODE	COMPONENTS	QTY
(A)	BODY	x01
(B)	SHELF	x03

HARDWARE CHECK LIST

CODE	DESCRIPTION	QTY
(01)	SHELF PIN 	x12

- PLEASE DO NOT DISCARD ANY OF THE PACKAGING UNTIL YOU HAVE CHECKED ALL THE PARTS AND THE PACKS OF HARDWARE.
- BEFORE YOU BEGIN TO ASSEMBLE YOUR NEW PIECE OF FURNITURE, PLEASE CHECK TO ENSURE THAT ALL PARTS HAVE BEEN SUPPLIED.
- FOLLOW INSTRUCTIONS CLOSELY AS DEVIATION FROM THEM MAY VOID YOUR WARRANTY AND PRESENT A POSSIBLE SAFETY RISK.
- IT IS RECOMMENDED THAT ASSEMBLY IS DONE ON A SOFT SURFACE LIKE CARPET TO AVOID ANY DAMAGE.
- PERIODICALLY CHECK AND RE-TIGHTEN ANY FASTENERS. WIPE DOWN ALL SURFACES WEEKLY WITH A CLEAN CLOTH. DO NOT CLEAN ANY SURFACES WITH HARSH ABRASIVES OR CHEMICALS.

1.

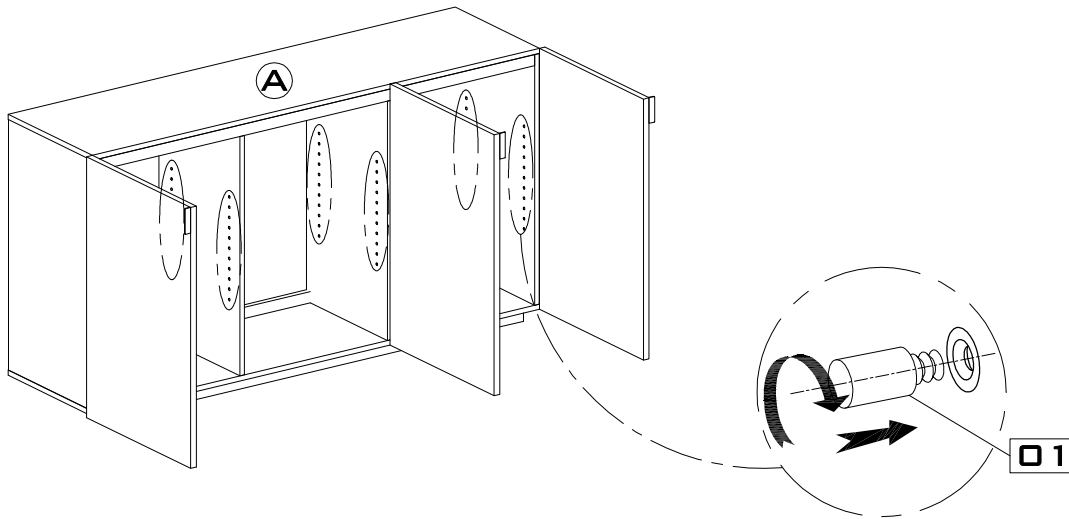

2.

ADJUST FEET LEVELERS

